

REMINGTON AUTOMATIC PISTOL

MODEL 51

List of Component Parts

Part No.	NAME OF PART	Part No.	NAME OF PART
1	Action Spring	57	Magazine Lock Spring
80	Action Spring Bushing	62	Main Spring Plug
306	Barrel	63	Main Spring Plunger
12	Barrel Lock Pin	64	Main Spring Rod
309	Breech Block	71	Receiver Plug
309 1/2	Breech Block Complete	75	Safety Lever
99	Cleaning Rod	76	Sear
18	Cocking Roll	77	Sear Pin
23	Disconnector	78	Slide Complete
27 1/2	Disconnector Complete	82	Sear Lock Lever
29	Ejector	83	Sear Lock Lever Pin
30	Ejector Pin	85	Sear Lock Spring
31	Ejector Spring	281	Stock, Right, Complete
36	Firing Pin	86	Stock Plate (2)
37	Firing Pin Spring	88	Stock Stud (4)
34 1/2	Grip Safety Complete	91	Trigger
42	Hammer	91 1/2	Trigger Complete
46 1/2	Hammer Complete	92	Trigger Lever
352	Magazine Tube Complete	93	Trigger Pin
54	Magazine Follower	94	Trigger Spring
		95	Trigger Spring Plunger

Supply of parts not listed is exhausted

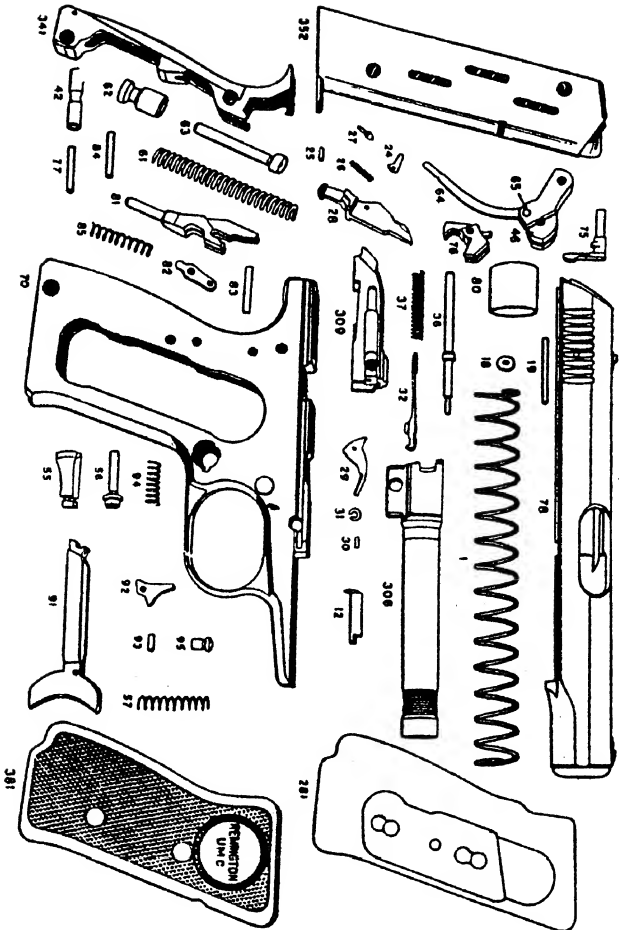

In ordering parts for repair, specify caliber, give each part number, together with its name, and if not convenient, also send the parts you desire to replace. Likewise, give the number of your pistol, which is stamped on the left side of the receiver.

RDS5525 Rev. 4-4-1M

DISMOUNTING AND ASSEMBLING

Remington

MODEL 51 AUTOMATIC PISTOL

Adapted for .32 and .380 Cartridges

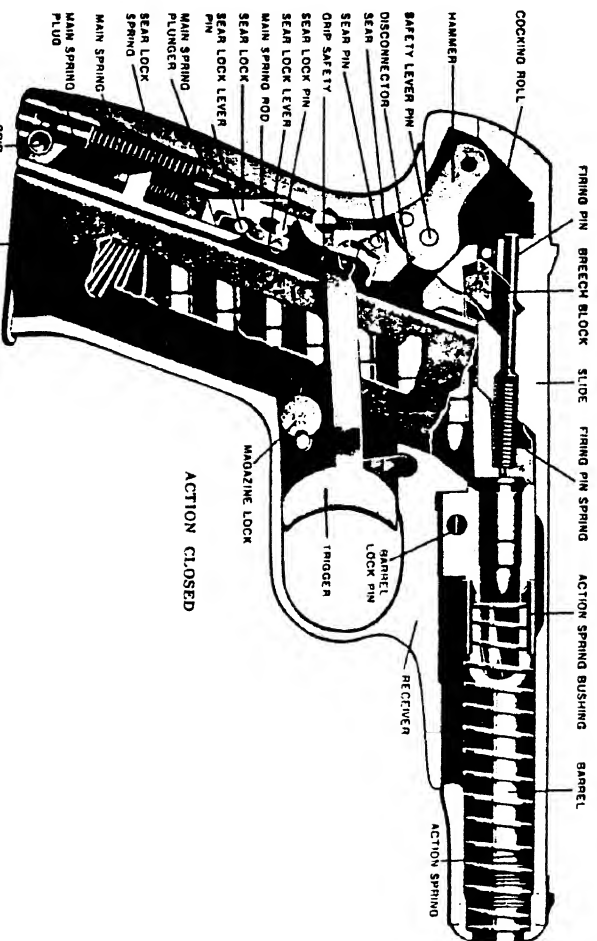
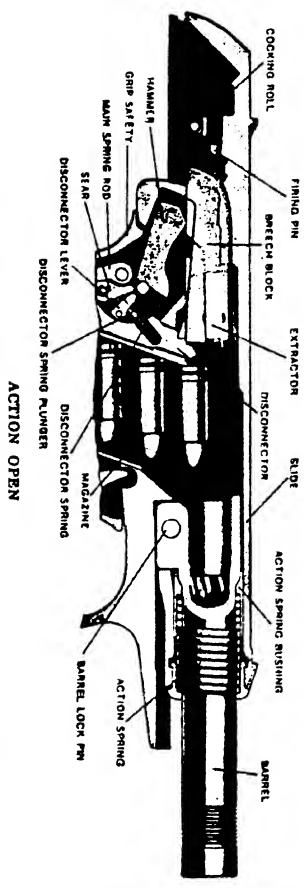

Any information desired in the future as to operation, repair, or refinishing of this gun may be obtained by addressing the factory at Ilion, N. Y.

REMINGTON ARMS COMPANY, Inc.

Ilion, N. Y., U.S.A.

REMINGTON

REMINGTON

DISMOUNTING AND ASSEMBLING

DISMOUNTING

1. Slide

Draw slide fully rearward, turn thumb safety up to lock slide open. Press magazine lock and remove magazine. Be sure the barrel is empty. Turn thumb safety down to let slide close. Grasp pistol as in Figure 1 and pull slide rearward until semi-circular hole on left side fits in the wide groove of magazine bottom to push pin from right side and to lift it out from left side.

Push slide far enough rearward to expose grooved barrel surface near muzzle, grasp barrel at grooves (Figure 2) and pull barrel and slide forward off the receiver (Figure 3).

2. Slide Components

Slide holding barrel in same manner, grasp slide upside down (Figure 4). Pull barrel out until it may be turned to left and caught upon slide lug; action spring will hold it there.

To remove breach block (Figure 5), push block rearward with thumb, pick up rear end with finger nail to clear slide lug as spring moves block forward, clear of firing pin, and lift block out. Lift extractor from block.

Tilt muzzle downward, firing pin and spring will fall out.

To remove barrel (Figure 6), turn barrel to release from stop shoulder and let it move slowly rearward in slide as far as spring will go, then push barrel still farther. Grasp action spring, bushing (Figure 6), pull it forward with thumb and finger, tilt rear end of barrel until it can be pulled out rearward. Lift out action spring and bushing.

If needed, the hammer roll pin may be driven one and the roll removed.

3. Stocks

Insert magazine and pull trigger to uncock hammer; remove magazine.

Hold receiver as in Figure 7, lay barrel on a firm surface, and place mainspring plug on side of barrel as shown. While grasping action spring, pull receiver, push grip safety pin out with firing pin. Remove grip safety.

Hold receiver as in Figure 8, push screws downward to stop, then lift off, raising rear edge first.

4. Receiver Components

Sear Lock—With firing pin, push out sear lock pins and remove sear lock with lever and spring.

Magazine Lock—Hold receiver as in Figure 9, press left end of magazine lock with point of firing pin until magazine lock follower disengages, then release follower with spring and remove lock.

Hammer—Cock the hammer. Move safety lever forward of sear pin hole the width of the hole as in Figure 10. Use firing pin to push out safety lever pin and sear pin. Depress side arms of trigger (which pass around magazine to reach disconnector) and sear, hammer (with mainspring rod attached) and disconnector may be shaken out.

Mainspring rod should not be detached from hammer, ejector from receiver, or lever from disconnector unless needed. In such case, push out the pin.

ASSEMBLING

5. Trigger

Slide it into receiver slot from rear, depress spring lever forward to pass under receiver shoulder.

6. Magazine Lock

Hold receiver as in Figure 9, insert lock from right side, and hold it in position with finger underneath; put follower with spring attached into hole from left side with collar of follower resting upon small end of lock. Use point of firing pin to press both lock and follower into hole until lock can swing sideways, push follower enough deeper to allow groove of lock to engage collar of follower, release pressure and lock will come to position.

7. Hammer, Sear and Disconnector

Drop disconnector into place, with sloping surface of its point toward rear. Depress arms of trigger and allow notched bar composing its rear end to engage lower end of disconnector, tipping receiver forward to assist in this. Insert hammer, with head of main spring rod forward. Secure it with safety lever. Set hammer in cocked position. Replace sear (in position shown in action closed), press it from rear with finger till holes through sear and receiver sit in line, and insert pin.

8. Sear Lock

Lift hammer to forward position with mainspring rod, and hold there; grasp receiver as in Figure 10. Assemble sear lock with spring into receiver (as shown in action closed) and put in two pins.

9. Stocks

Lay stock upon receiver with front edge touching to engage metal stock plate with undercut of receiver as in Figure 8; swing stock to rest flat and slide it endwise toward top of receiver, which will engage rear edge of metal stock plate with undercuts of receiver.

10. Grip Safety

If hammer is in cocked position, insert magazine, pull trigger, and move hammer forward to its stop. Hold receiver as in Figure 11, place grip safety in position, being careful to get end of mainspring rod properly seated against mainspring plunger. Put in grip safety pin while holding receiver, and pressing inward the mainspring plug.

11. Barrel

Action spring, breach block and firing pin to slide. Put action spring into slide, fit bushing in rear end, compress spring, and work bushing part way down in magazine in slide, holding parts as in dismounting shown in Figure 6. Insert barrel and depress barrel and bushing completely into magazine. Push barrel forward and lock in position shown in Figure 4.

Assemble spring to firing pin, put spring end of firing pin assembly into breach end of barrel, drop rear end of firing pin upon sloping surface of lug in slide. As pin engages hole in lug, raise muzzle and pin will slide into its place. Replace extractor in breach block.

Drop front end of breach block in its place at rear of barrel, lower rear end of block, and push to rear by pressure on its front end until it snaps into position.

12. Slide Complete to Receiver

Remove magazine if in receiver, cock the hammer. Engage rear end of slide with front end of receiver and move it rearward as in Figure 3. Push ejector down.

Grasp barrel and rotate it until face of stop shoulder in slide and lug will enter slot in top of receiver. Move slide until semi-circular hole on left edge is in line with barrel lock pin hole and insert the pin from left side. Release the slide and put magazine into position.

Pistol is now complete and ready to operate.

